

PIM3D TEST FIXTURE	TF-PIM3D-50W-TDD-PCB
T110	
APPLICATIONS	
<ul style="list-style-type: none"> ◆ QUICK SET UP FOR PIM3D 50W TDD MODULES EVALUATION ◆ COMPATIBLE WITH TDD MODULES ◆ MEASUREMENT STANDARD FOR PIM3D MODULES ◆ 100MHz-4GHz 	
	

Block diagram:

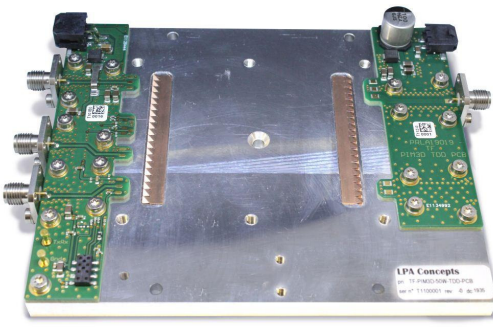
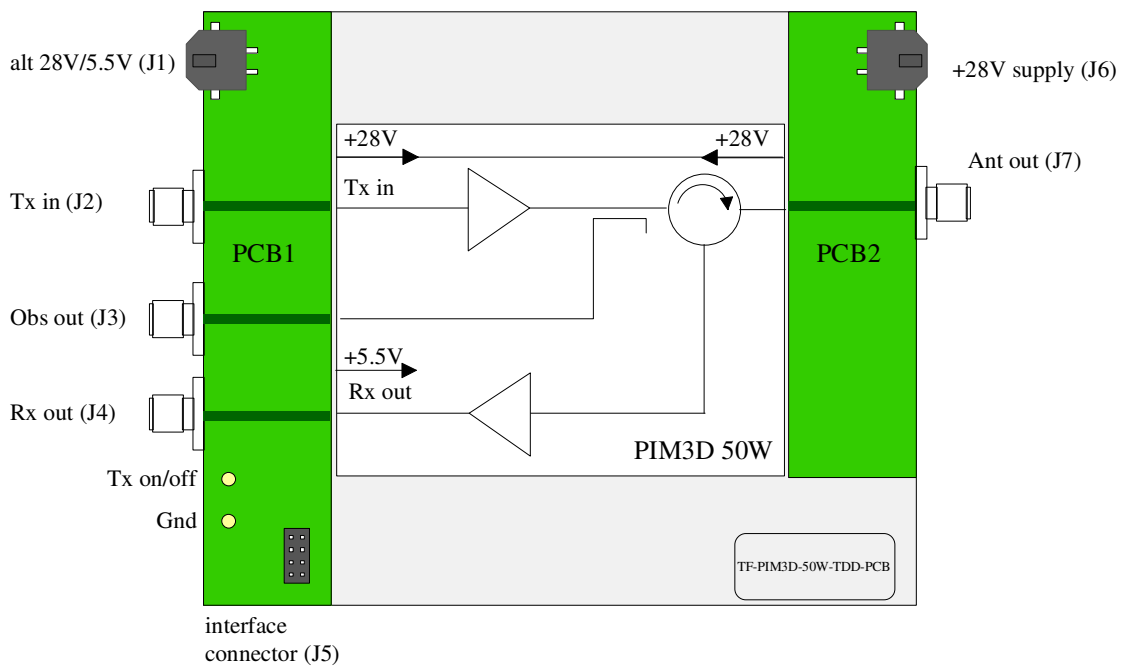

Electrical characteristics: 50 ohms Load module

Ref	parameter	conditions	note	min	typ	max	units
1	Return loss Tx in	0-4GHz		-18	-22		dBc
2	Return loss Obs out	0-4GHz		-18	-22		dBc
3	Return loss Rx out	0-4GHz		-18	-22		dBc
4	Return loss Ant out	0-4GHz		-18	-22		dBc
5	Isolation Tx in - Obs out	0-4GHz		-70	-75		dBc
6	Isolation Tx in - Rx out	0-4GHz		-75	-80		dBc

Mechanical :

Ref	Designation	Description	Remarks
1	Base plate size	100.0 mm x 120.5mm x 7.0mm	
2	PIM3D Mounting	6 M3 x 8 CHC Screws (supplied with T100)	Do not use thermal grease between PIM3D and base plate
3	PCB1	FR4 multilayer board 1.6mm thick	See APNT18002C for outline
4	PCB2	FR4 double sided board 1.0mm thick	See APNT18002C for outline

Connectors :

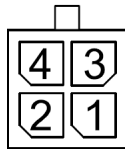
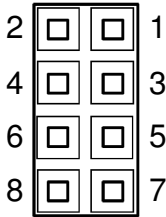
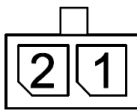
Ref	Type	Description	Remarks
J1	28V/6V DC POWER (1) Molex Microfit Header 43045-0409 Mate with Molex Microfit Receptacle Housing 43025	1, 3 : GND 2 : +28V 4 : +6V	
J2	RF Tx input	SMA female	
J3	RF PA Observation Output	SMA female	
J4	RF Rx output	SMA female	
J5	Interface connector 2x4 2mm female Samtec CLT-104-02-D-A	1 ALCRX 2 PA Mute (3) PA Mute= 0V ⇒ TX OFF PA Mute= 3V ⇒ TX ON 3 Preverse 4 28V 5 I2C : SDA 6 Gnd 7 I2C : SCL 8 NC	
J6	28V DC POWER from output (1) Molex Microfit Header 43650-0213 Mate with Molex Microfit Receptacle Housing 43645	1 : GND 2 : +28V	
J7	RF Ant output	SMA female	

- (1) cable equipped with banana plugs is provided with T110 for quick start up
 (2) 28V can be supplied either through J1 or J6. J6 can be preferred in applications.
 (3) pin2 of J5 is also connected to TxRx post on PCB for ease of connection for TDD module test.

Specifications and information are subject to change without notice

Base plate configuration :

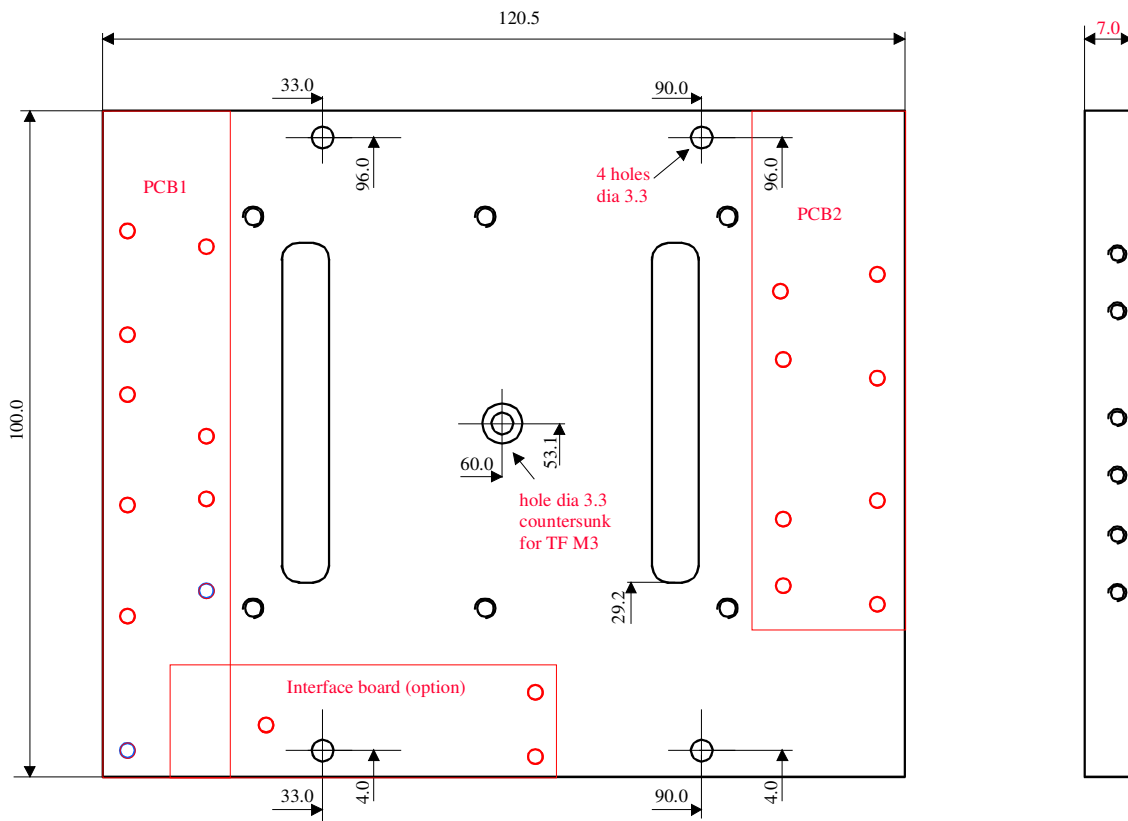

Mounting holes for heatsink (option) : 4 CHC M3 + TF M3 countersunk under module

Mounting holes for interface board (option) : 3 M2.5 holes for PCB spacers

Accessories (options) :

Ref	Part number	Description	Product code
1	TF-PIM3D-50W-TDD-PCB-50R	50 ohms reference module	
2	TF-PIM3D-INTERFACE01	I2C to RS485 Interface board with GUI	T140
3	TF-PIM3D-50W-HS	Heatsink	T150

Notes :

- 1. T110 can be operated by itself. Options are aides to full evaluation and development.
- 2. Refer to specific PIM3D module specification for more information

Support documents:

Ref	Document type	Document number	Title	Date
1	Application Note	APNT17001B	PIM3 Module product line	12/2018
2	Application Note	APNT18002C	Using PIM3D modules	12/2018

TYPICAL PERFORMANCE (with 50ohms load module)

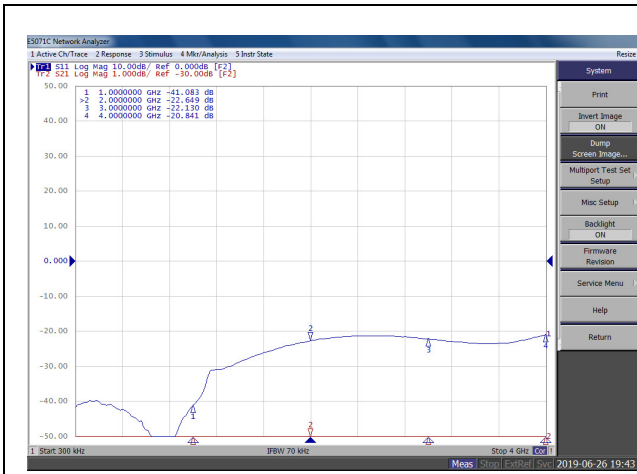

TX IN RETURN LOSS

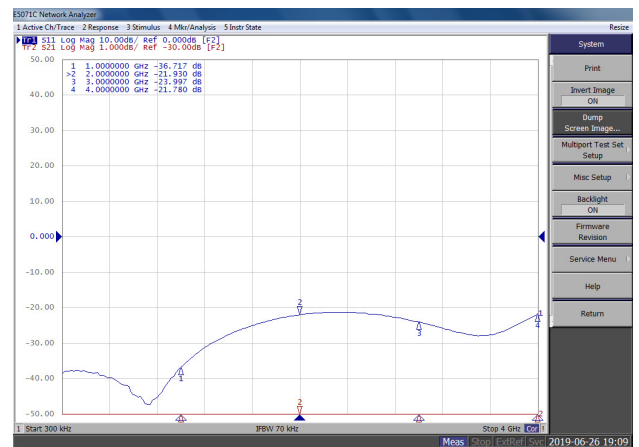

OBS OUT RETURN LOSS



RX OUT RETURN LOSS

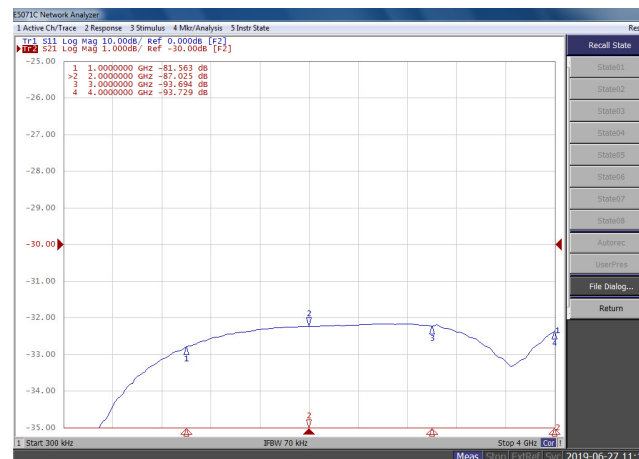

ANT OUT RETURN LOSS

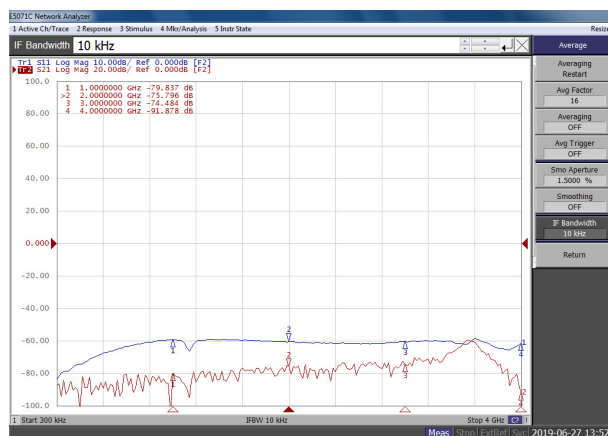

TX IN TO OBS OUT

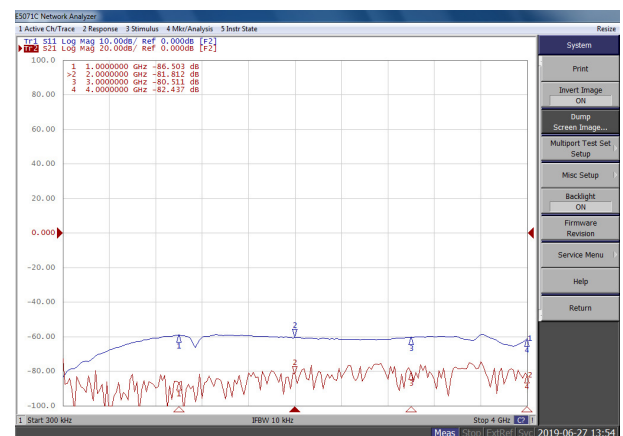

TX IN TO RX OUT

Specifications and information are subject to change without notice